

9 Schematic Diagrams

- This Document can not be used without Samsung's authorization.

9-1 INPUT

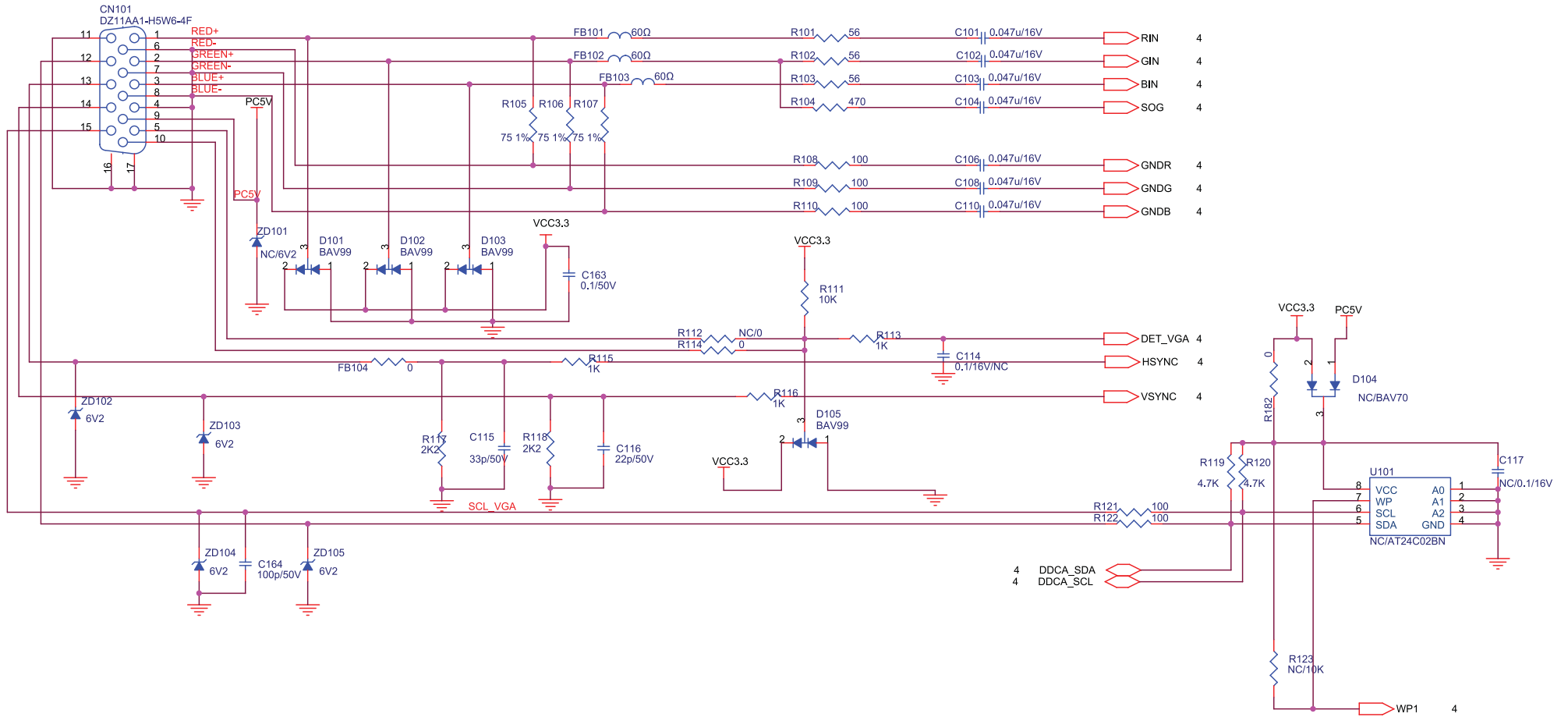

9-2 DCINPUT

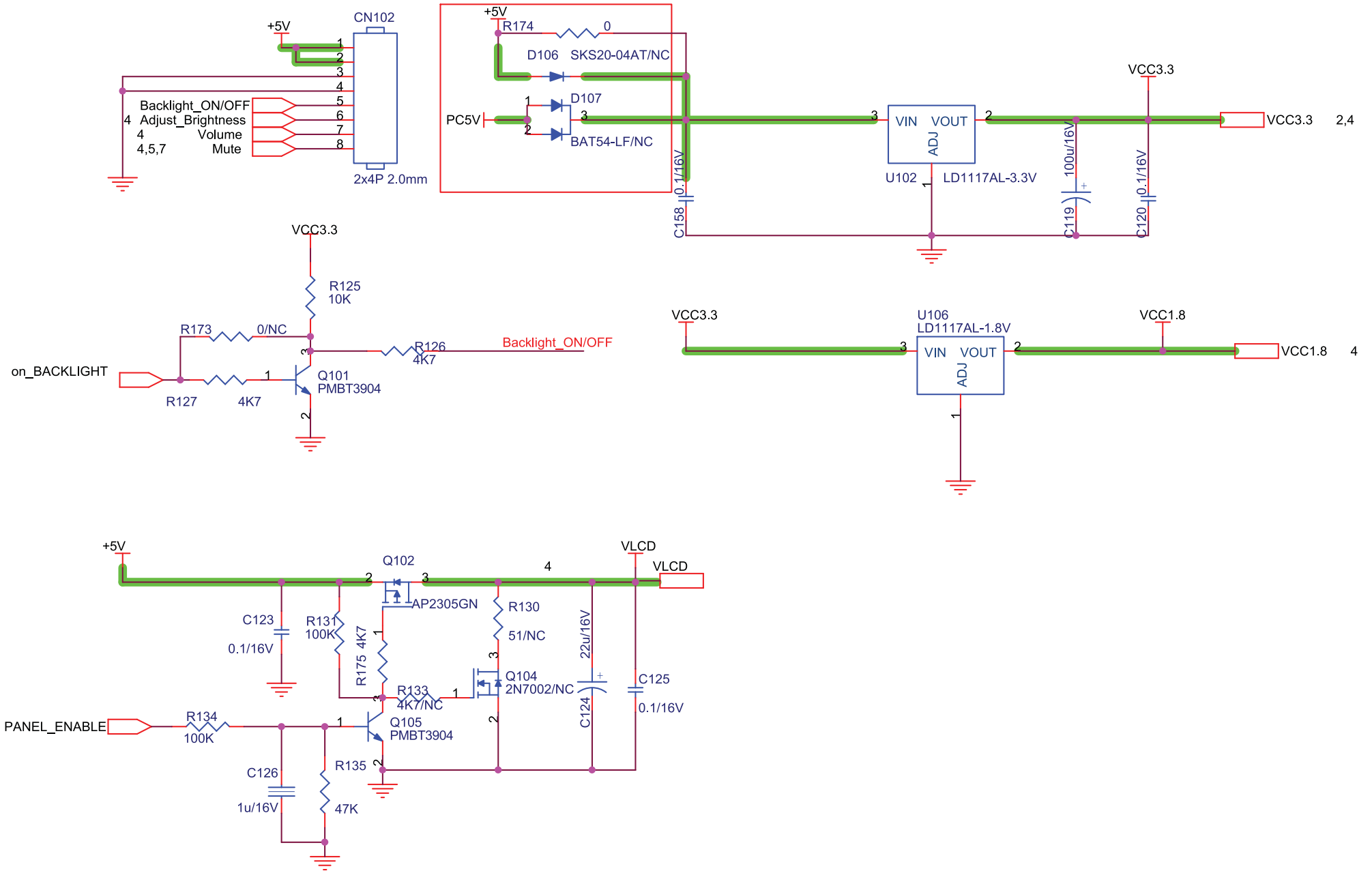

9-3 SCALER

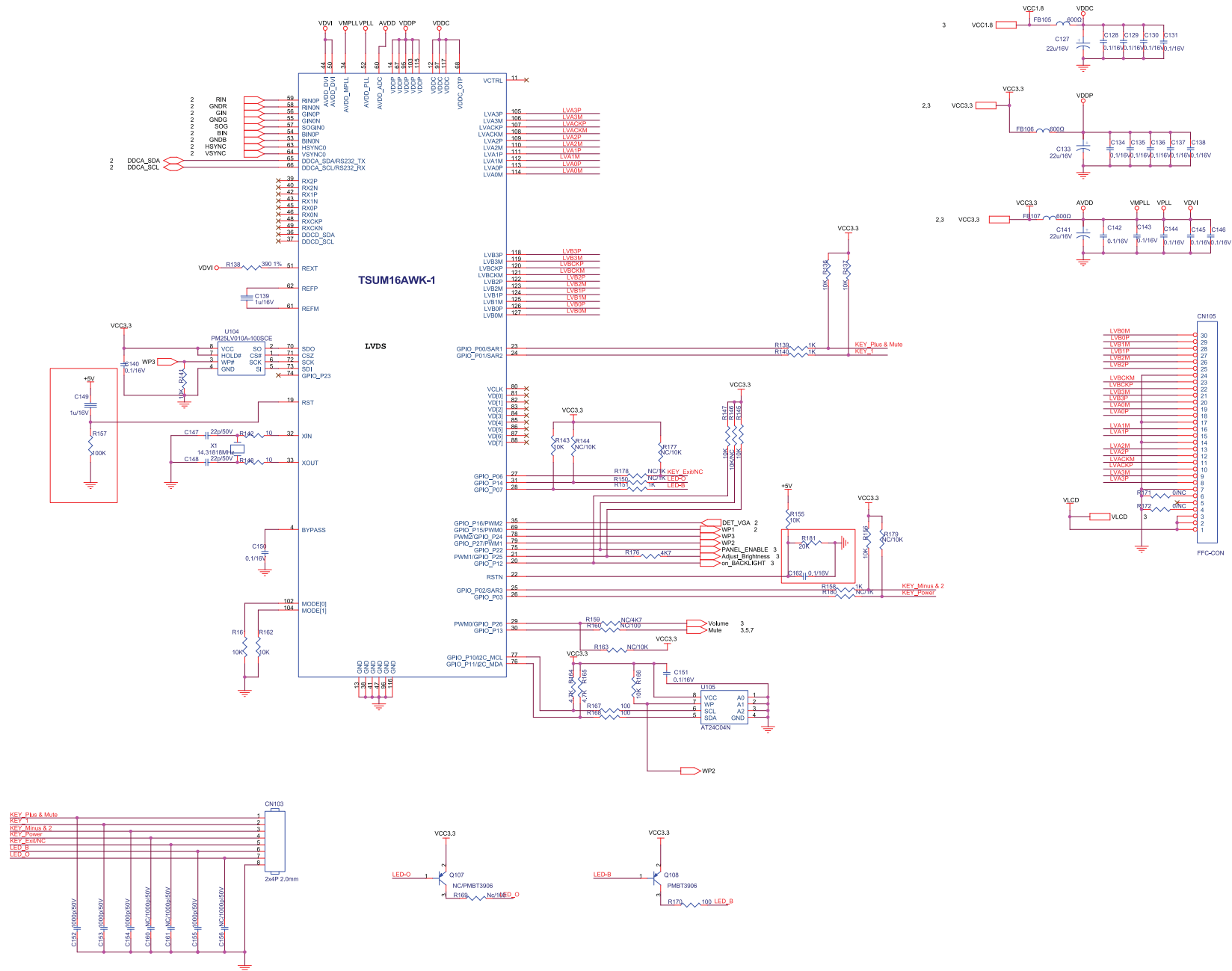

9-4 POWER

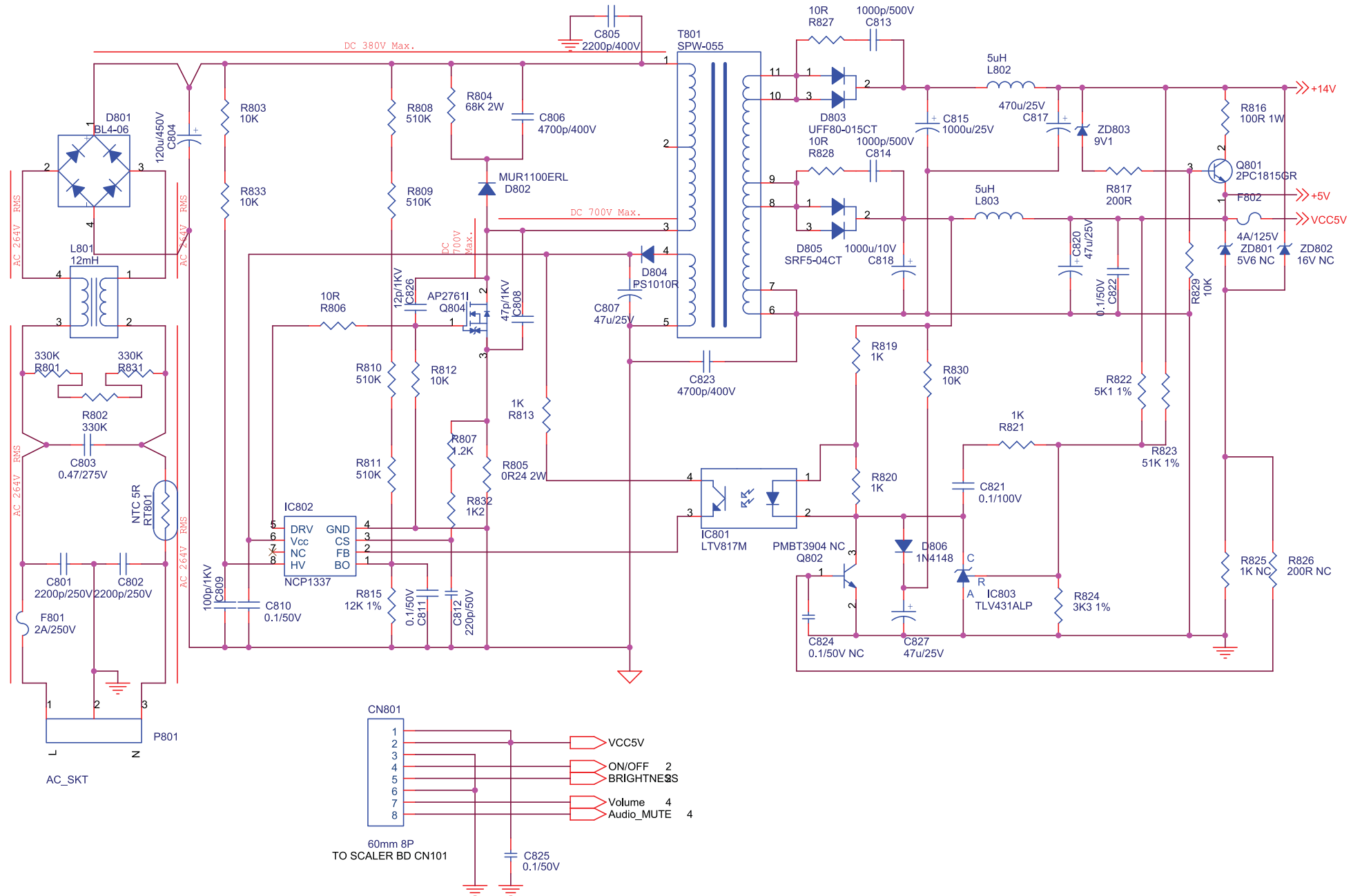

9-5 POWER

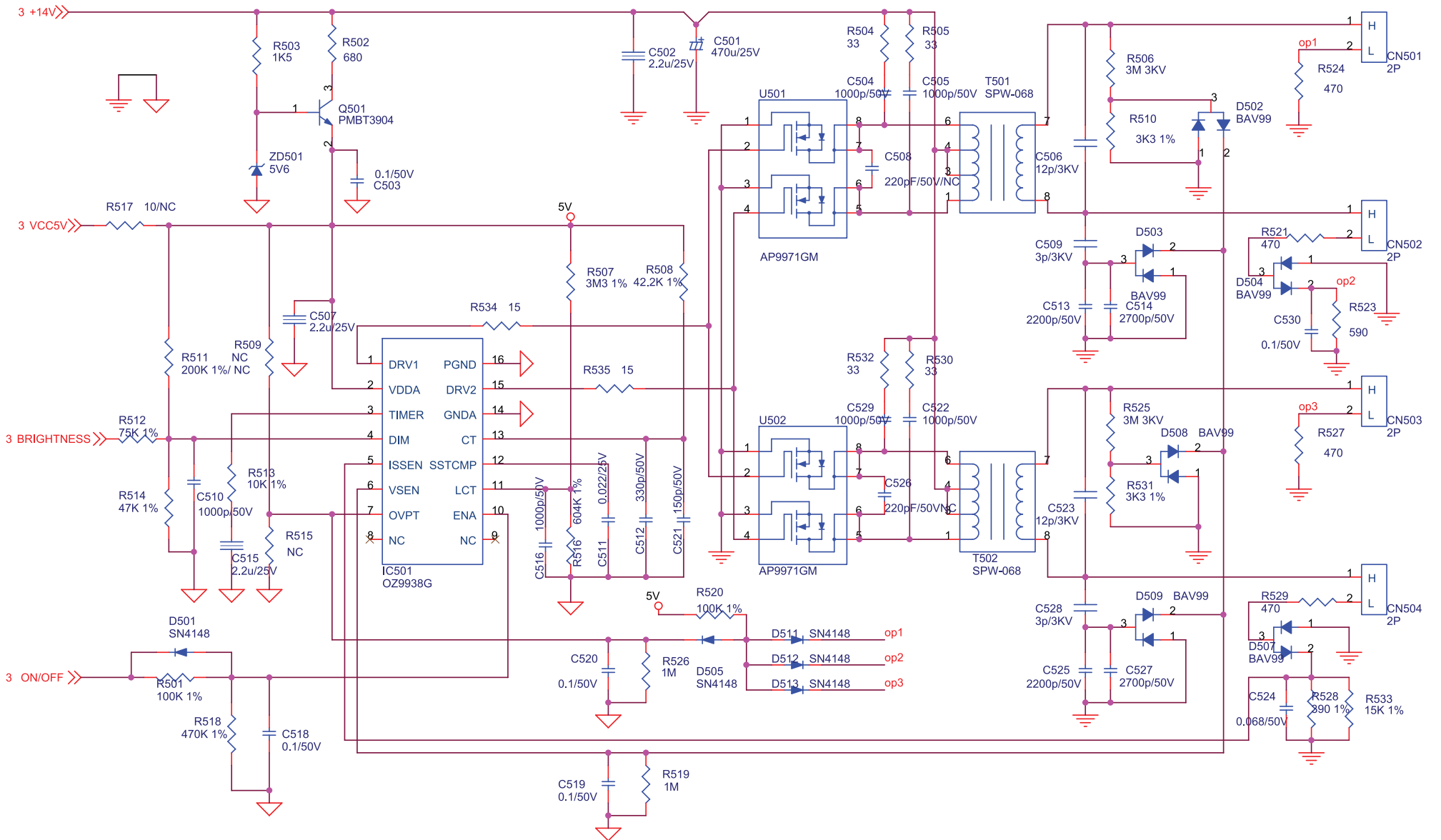

9-6 KEYPAD

